

Frontansicht / Front view

A →

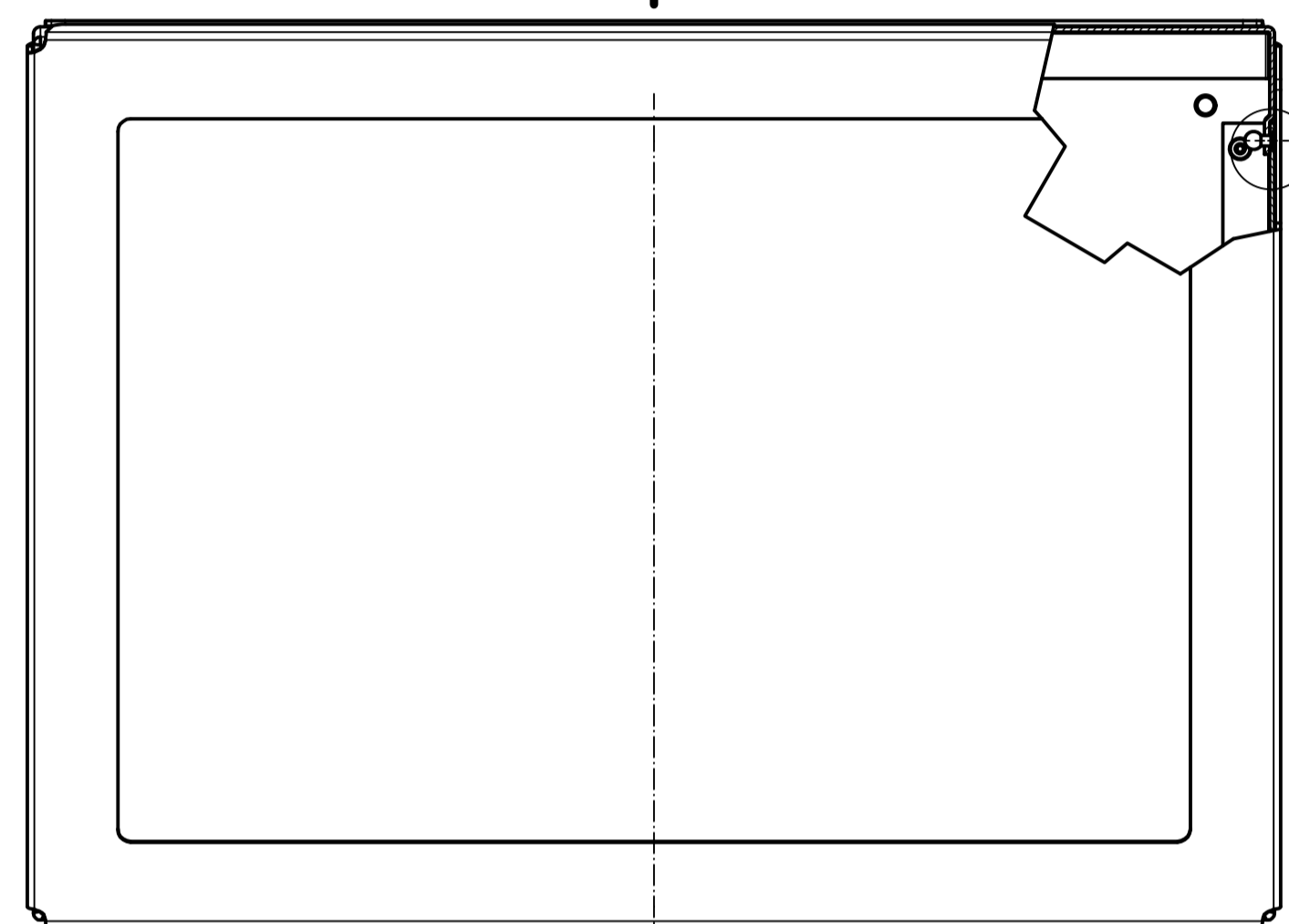

A →

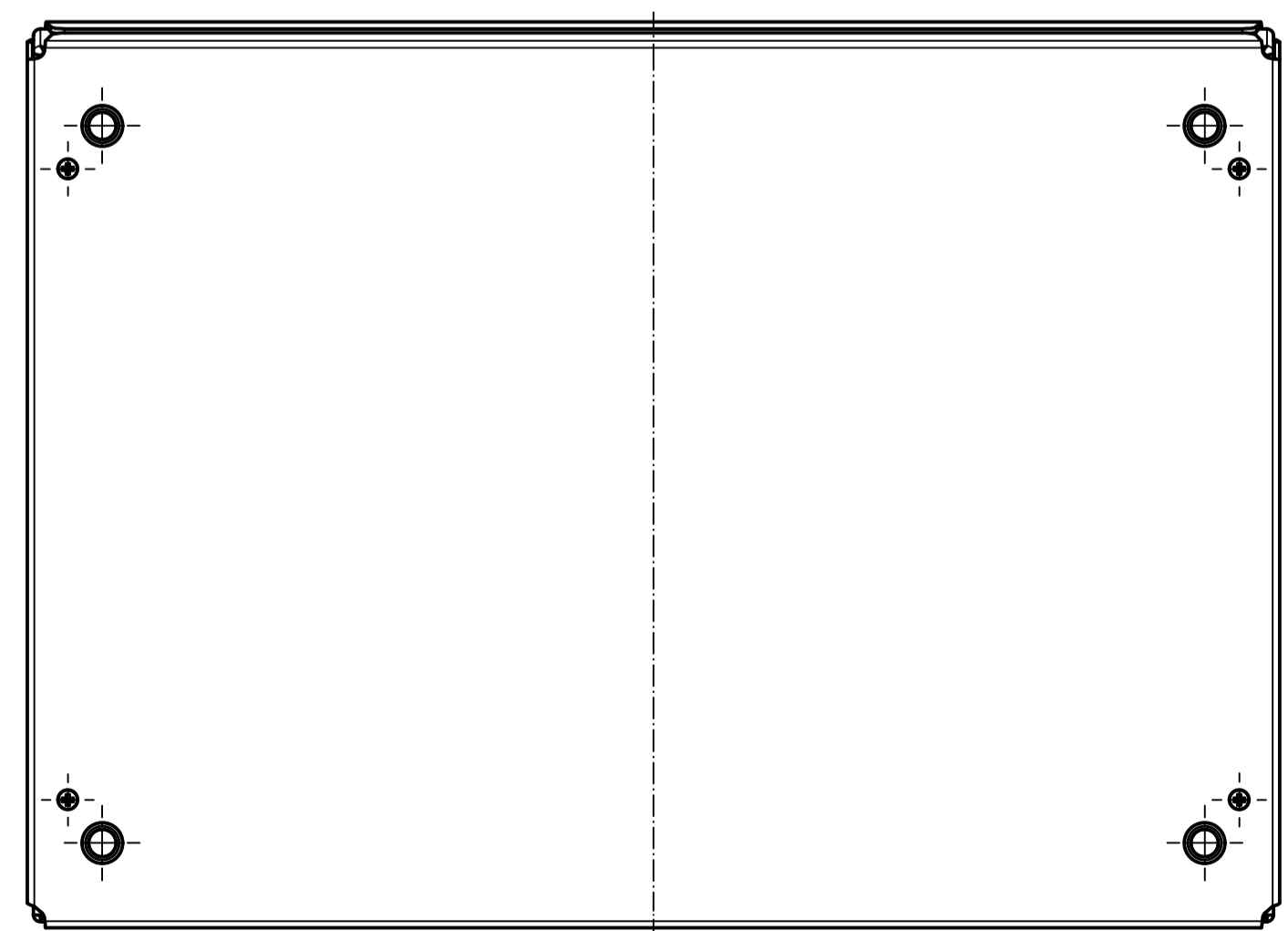
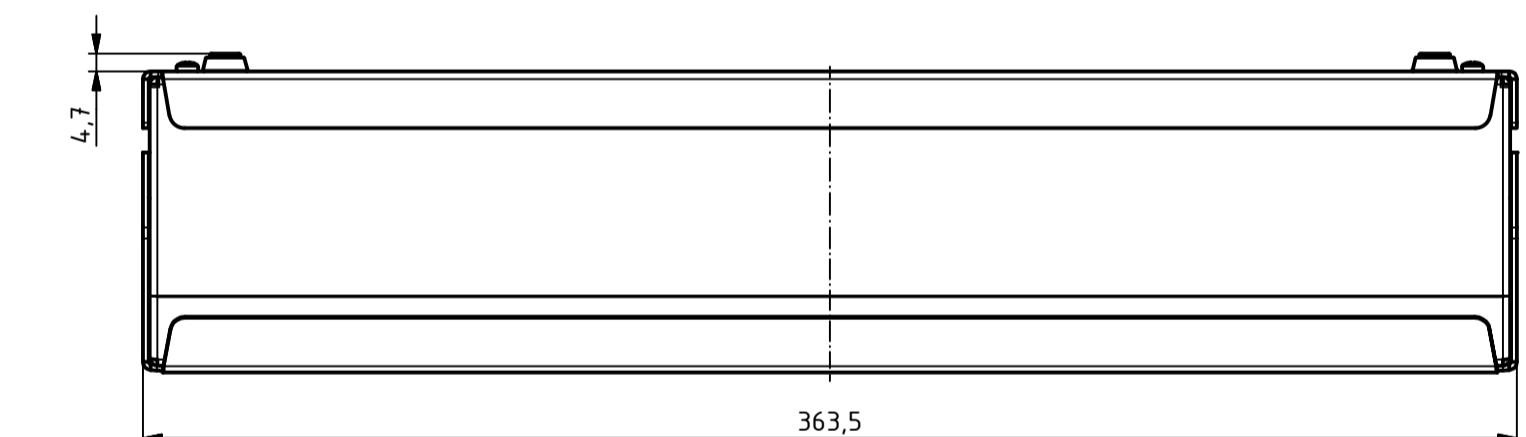

X (2 : 1)

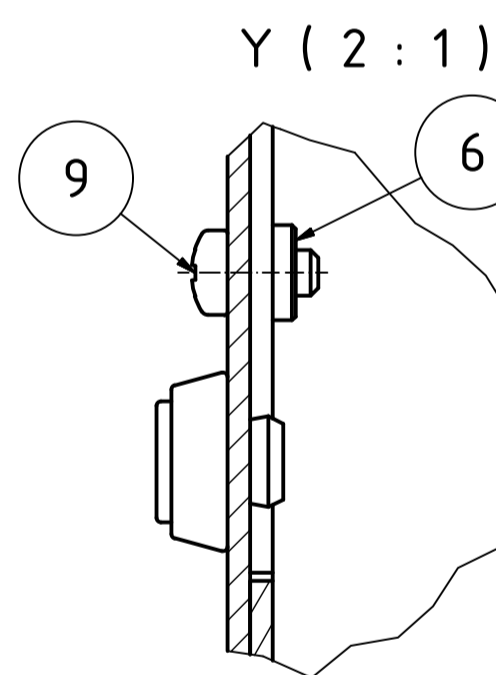
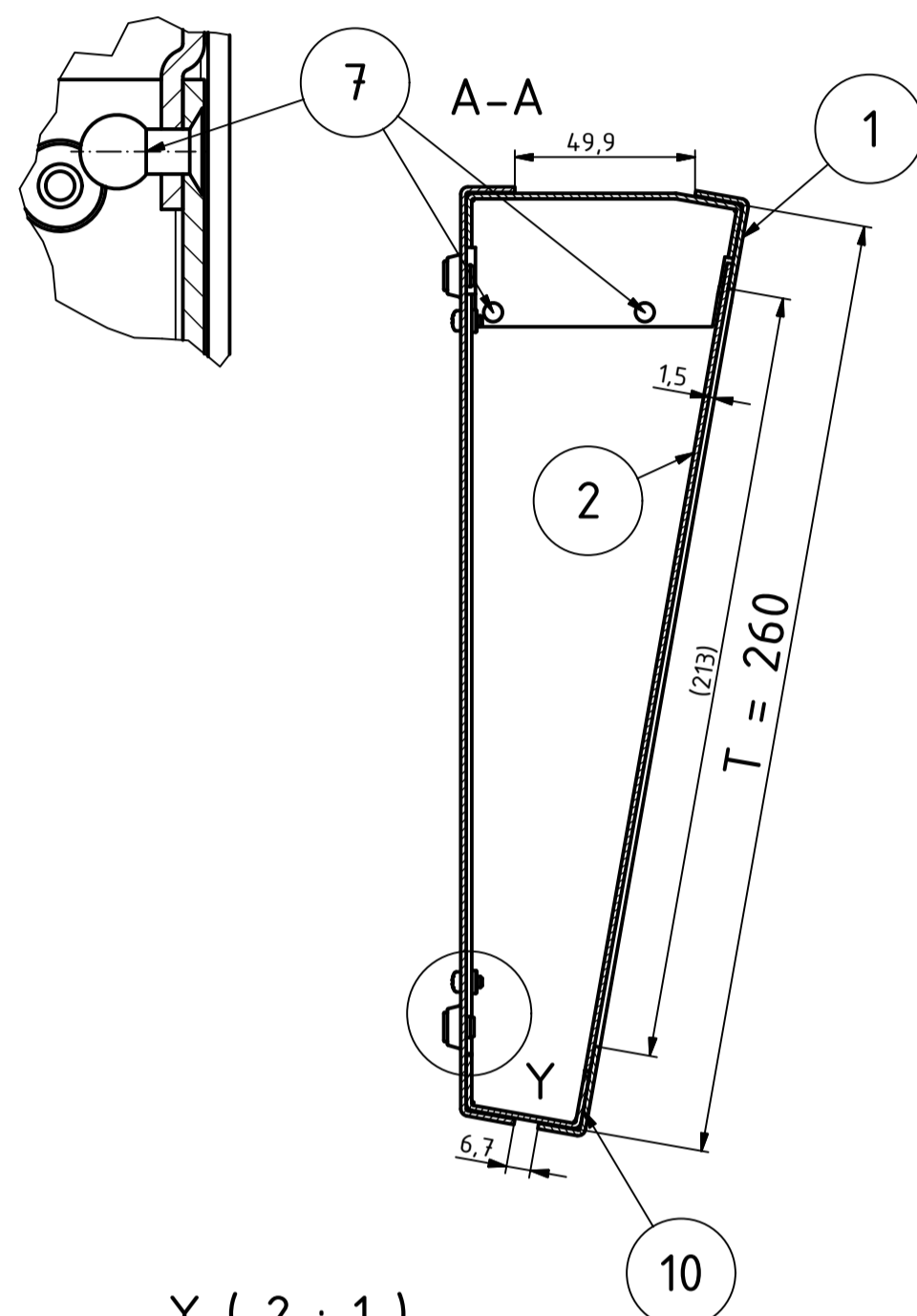

Ansicht D (1:2)

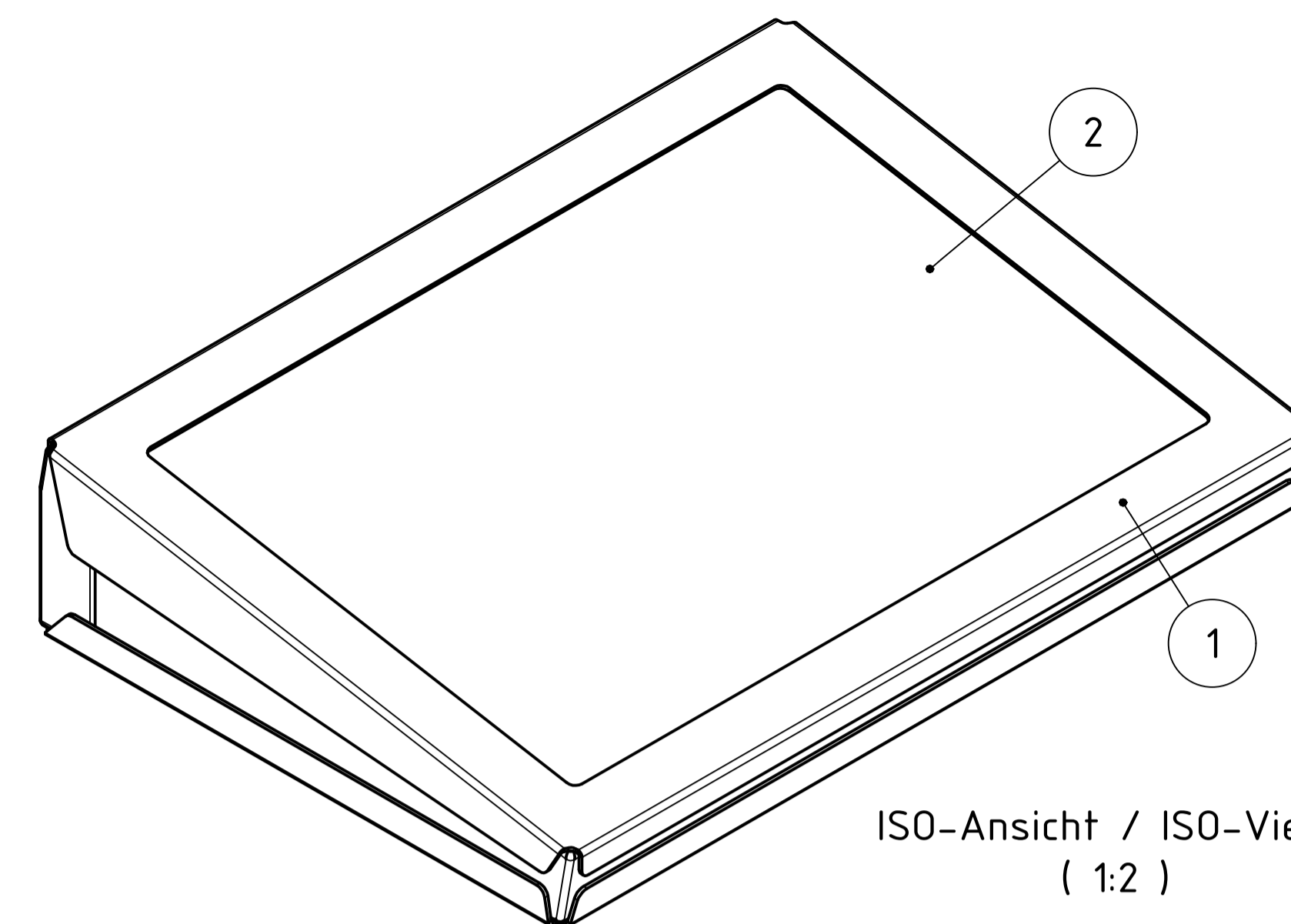
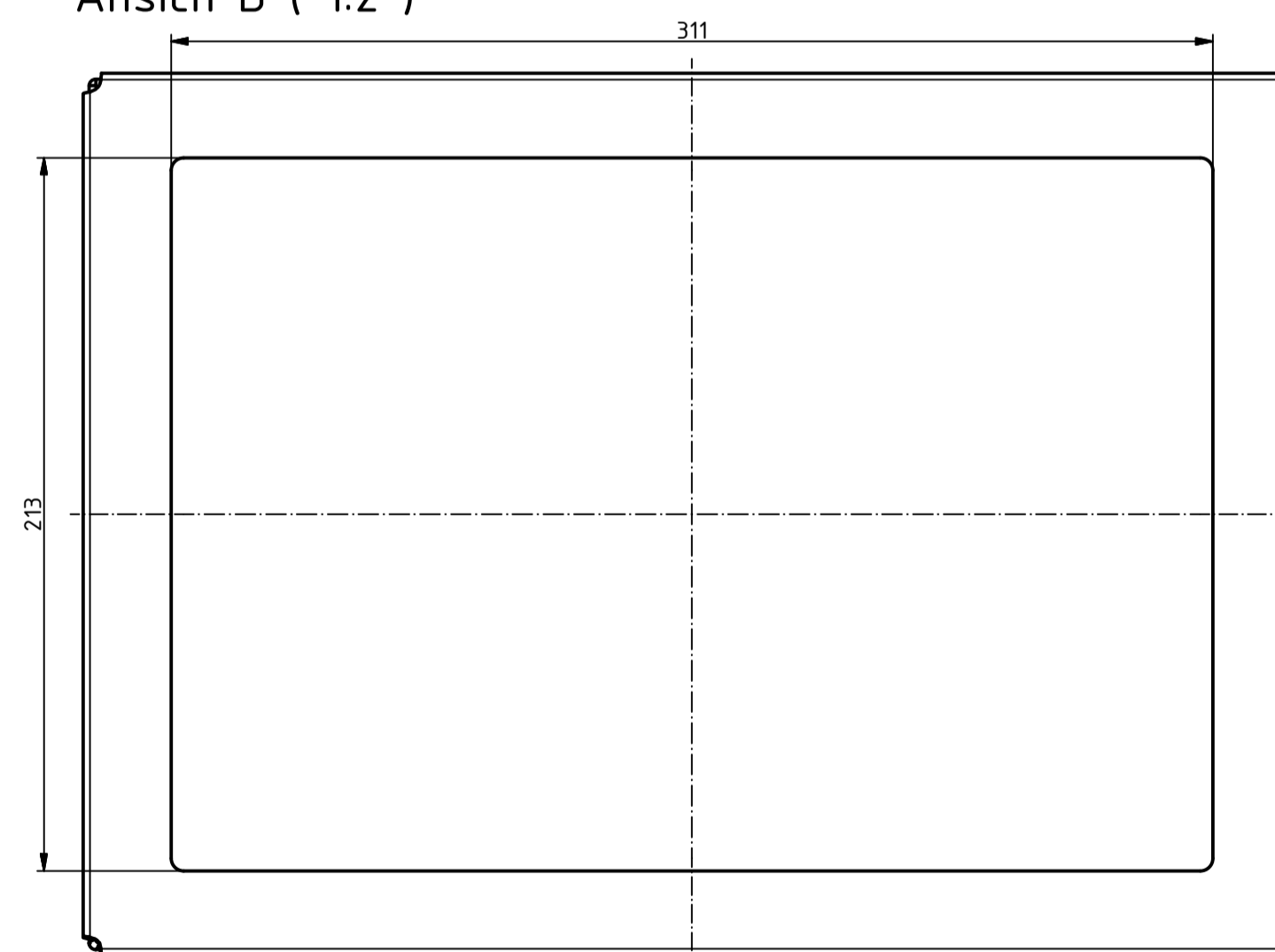

ISO-Ansicht / ISO-View (1:2)

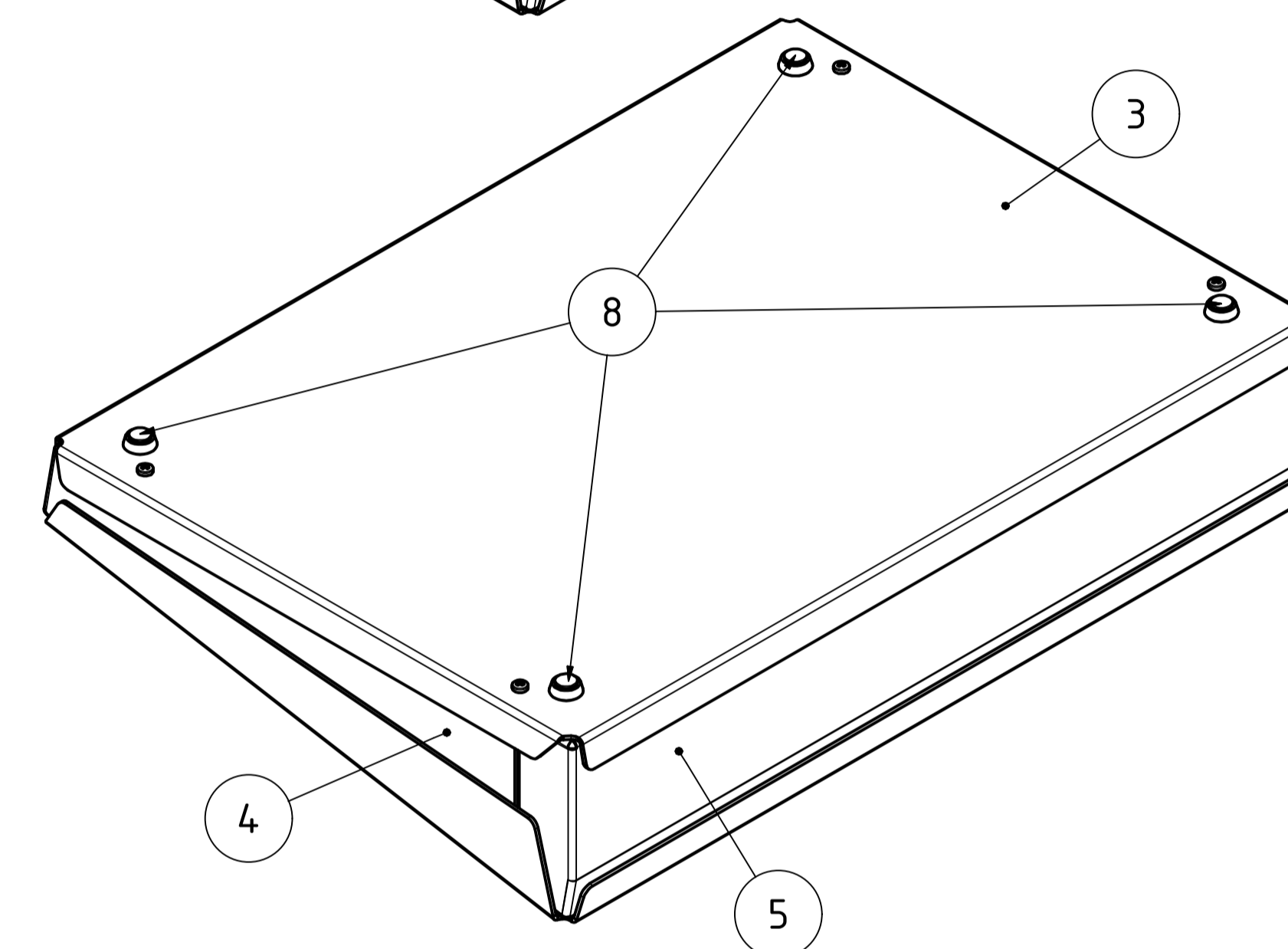

Oberflächenveredelung:
 nachträglich Pulverbeschichtet
 - Pulverart:
 DUPONT ALESTA FS mat (Feinstruktur)
 - Einzel-Teile komplett pulverbeschichtet,
 (als Korrosionsschutz)
 - Pulverschichtdicke min. 60µm
 - Farbe gemäß Stückliste

Surface finish:
 subsequently powder coated
 - Type of powder:
 DUPONT ALESTA FS mat (fine structure)
 - Parts completely powder coated,
 (as corrosion protection)
 - thickness of powder coating: min. 60µm
 - Color according bill of material

Werkstoff:
 Material:
 Allg.Tol.: DIN ISO 2768-mK für Bearbeitung
 Gen.Tol.: DIN ISO 2768-mK for machining
 Maßstab/
 Scale: 1:2 (2:1)

Zeichnungs-Nr. / Drawing-No.:
 1G 5427.022.01
 Bem.: Erstellt nach Vorlage / Dim.: constructed by specification

Artikel / Article:
 Interzoll Case Pultgehäuse
 IC/P 260336
 Grundzeichnung/Basic drawing

Pos.	ST	Modell / Model	Werkstoff / Material	Zeichnung / Drawing	Material-Nr.	Sonstiges / ect.
1	1	Abdeckung Oben	EN AW-5754-H22 (Alu roh / Alu raw) 1,5mm	Vorlage-Basis: 2A 5427.005.0		beschichtet / coated RAL 7024
2	1	Abdeckung Oben FP	EN AW-5754-H22 (Alu roh / Alu raw) 1,5mm	Vorlage-Basis: 2A 5427.005.0		beschichtet / coated RAL 7024
3	1	Abdeckung Unten	EN AW-5754-H22 (Alu roh / Alu raw) 1,5mm	Vorlage-Basis: 2A 5427.006.0		beschichtet / coated RAL 7024
4	1	Innenfeil Front Seite	EN AW-5754-H22 (Alu roh / Alu raw) 1,5mm	Vorlage-Basis: 2A 5427.007.0		beschichtet / coated RAL 9006
5	1	Innenfeil Rück	EN AW-5754-H22 (Alu roh / Alu raw) 1,5mm	Vorlage-Basis: 2A 5427.008.0		beschichtet / coated RAL 9006
6	4	KVT S-M3-2	Stahl, gehärtet, verzinkt, farblos passiviert / Steel, hardened, zinc-plated, colorless passivated		59003130	
7	4	BLINT 7337B AL/ST 3,0x8			59000296	
8	4	Gehäusefuß ø12x4		Firma Skiffy 120 0412 699 01	59001300	
9	4	SHR Z M3x6 DIN 7985 (ISO 7045)	A2		59000338	
10	1	3M VHB Klebeband 5909		Fa. 3M	59050100.M2	Länge / length: ca. 1240 mm