

Ausführung mit FP/FIP und PM/  
Version with FP / FIP and PM

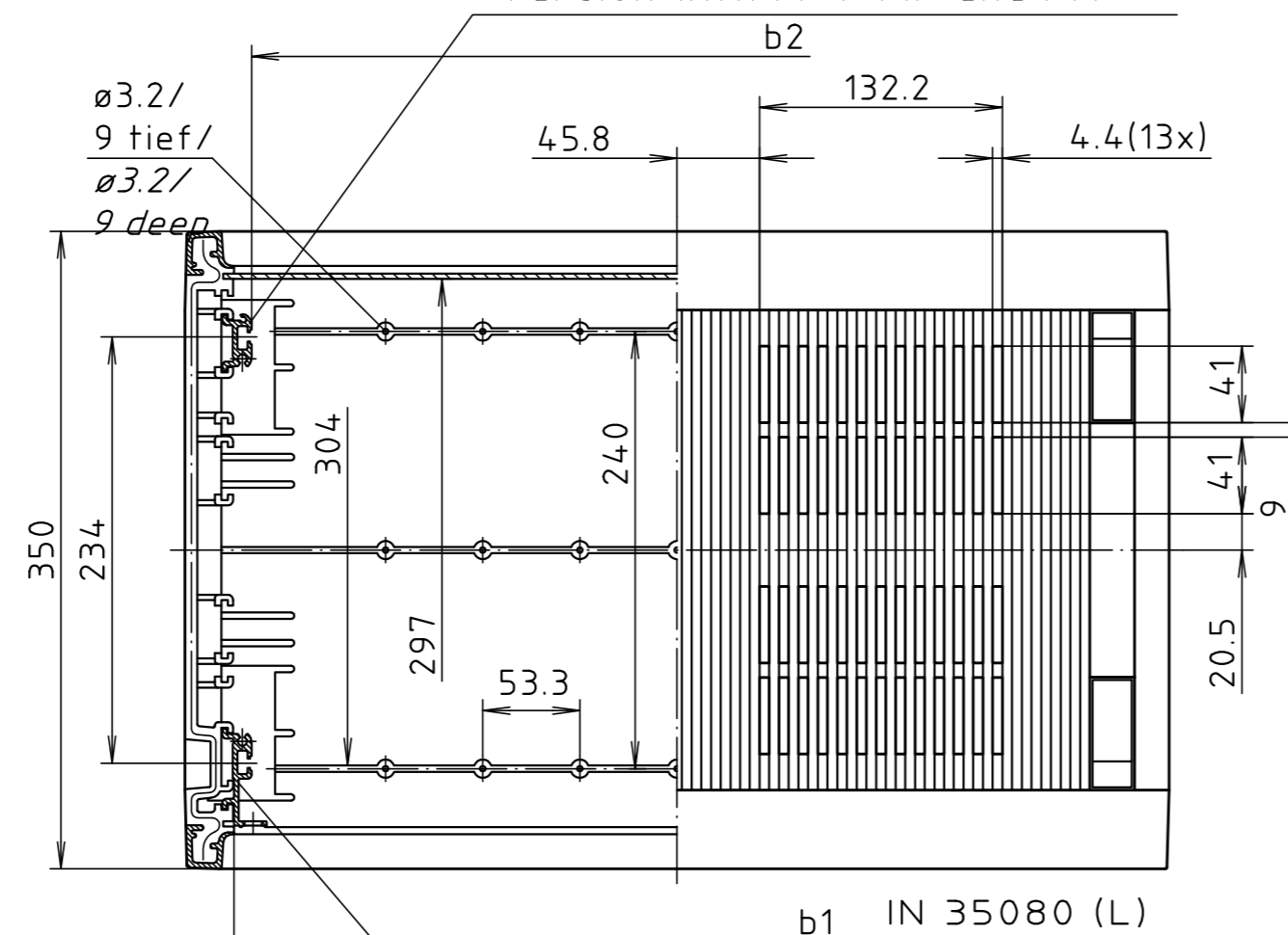

Ausführung mit PZ/  
Version with PZ

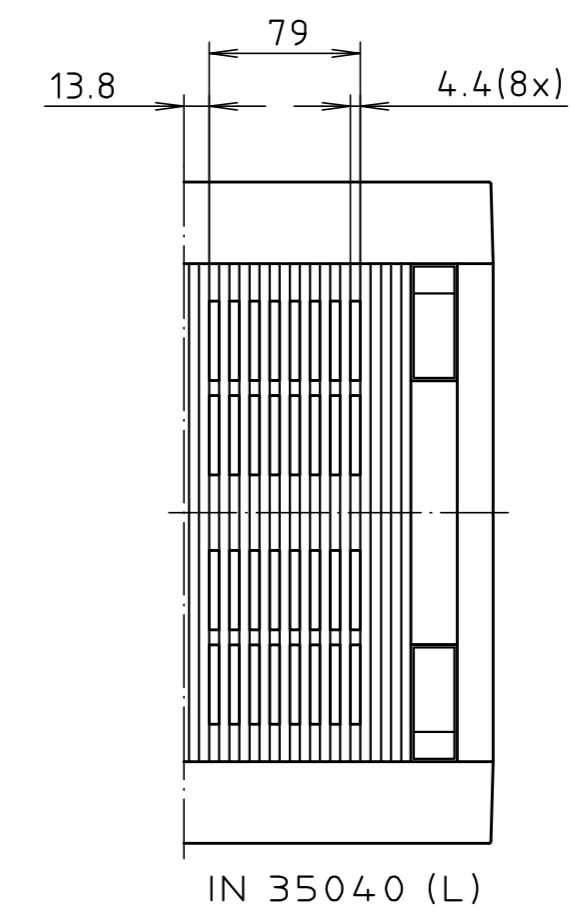
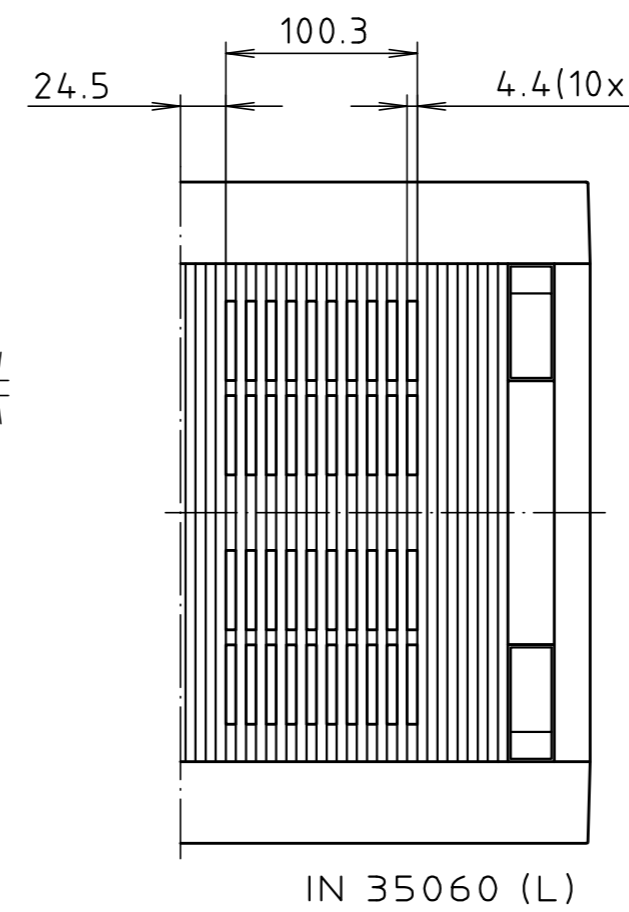

Modell/model	T (mm)	TE/HP	B	b1	b2
IN 35040	350	42	327	272	253
IN 35060	350	63	434	379	360
IN 35080	350	84	540	486	467

"Schutzvermerk nach DIN ISO 16016 beachten." "Please pay attention to copyright note DIN ISO 16016"

Maßstab/  
Scale: -

Zeichnungs-Nr. / Drawing-No.:  
2G 1900.801.02

Artikel / Article:  
Internorm  
IN 35080/35060/35040  
Katalogzeichnung / Catalogue drawing

3592	07.02.02
A.Nr./ Alt-No.:	Datum/ Date:

DISK: 2 200 505  
Datum/Date: 20.07.89 SM