

"Schutzvermerk nach DIN ISO 16016 beachten" "Please pay attention to copyright note DIN ISO 16016"

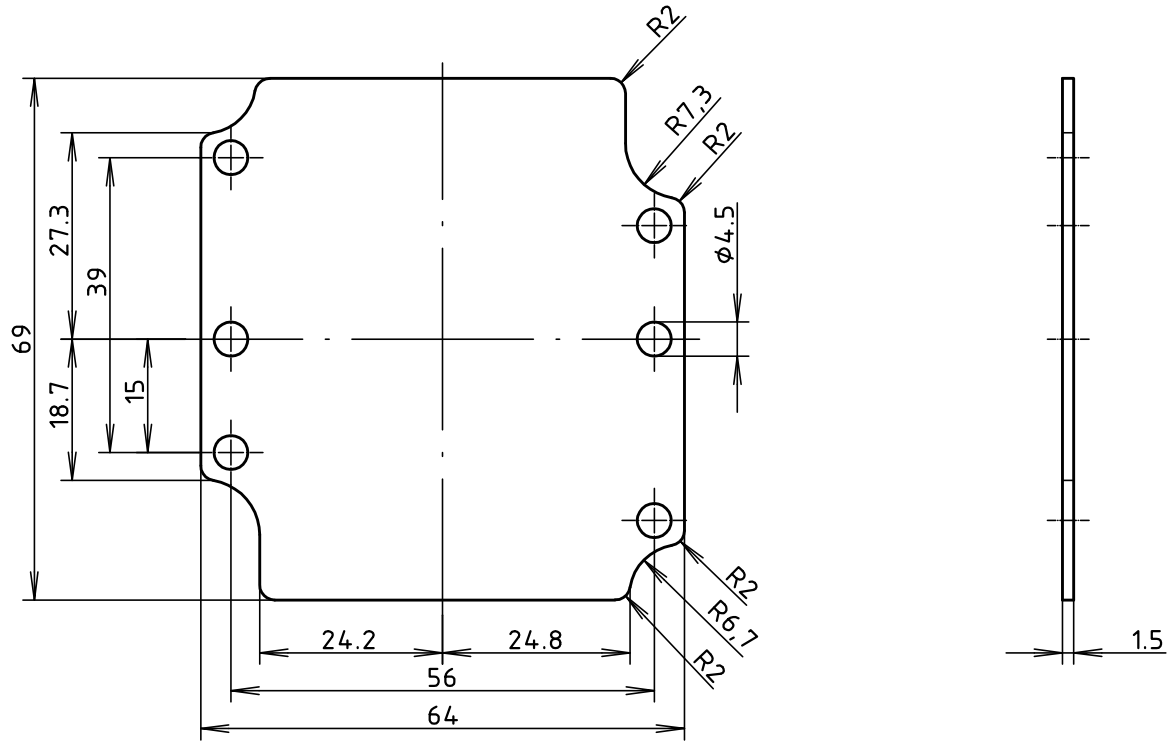

Maßstab/ Scale: 1:1 

Zeichnungs-Nr. / Drawing-No.: 4K 0105.005.02

Artikel / Article: Montageplatte / mounting plate  
A 105, PK 105  
Katalogzeichnung / Catalogue drawing

3596	23.04.2003
Ä.Nr / Alt-No.:	Datum / Date:



**BOPLA**  
A Phoenix Mecano Company

DISK: 2 400 261  
Datum / Date: -