

"Schutzvermerk nach DIN ISO 16016 beachten" "Please pay attention to copyright note DIN ISO 16016"

Anschlussquerschnitte

Leiterart	Aderquerschnitt	Abisolierlänge
Eindräftig (starr)	0.2mm ² -4.0mm ²	6.0mm
Feindräftig (flexibel)	0.2mm ² -2.5mm ²	6.0mm
Feindräftig mit Aderendhülse	0.25mm ² -2.5mm ²	6.0mm

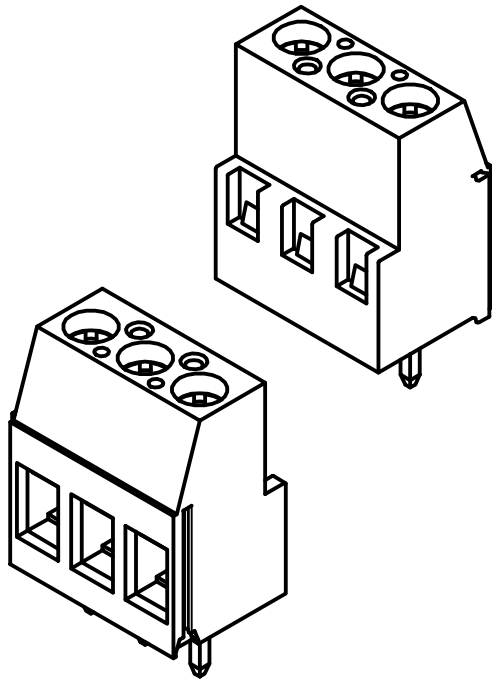
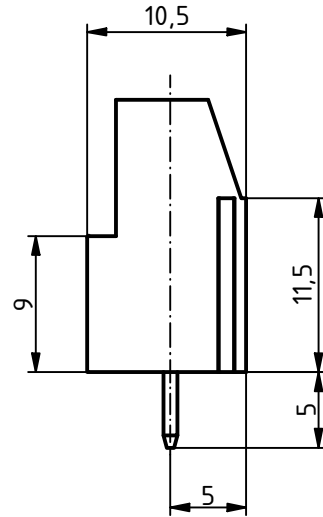
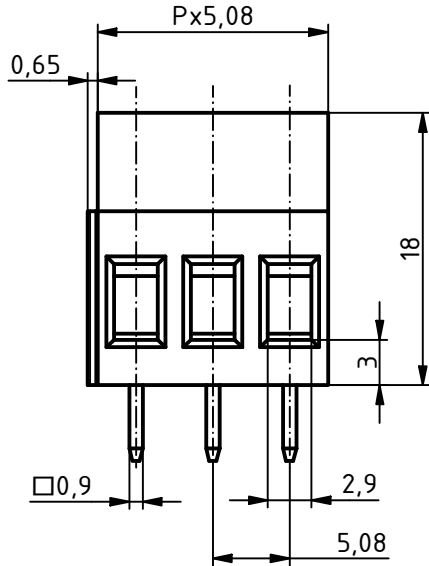

Maßstab/ Scale: 2:1

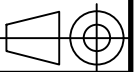

Zeichnungs-Nr. / Drawing-No.:
4K 5465.022.01

Artikel / Article:
AKZO 700/ _ 5.08 V Anschlussklemme
AKZO 700/ _ 5.08 V connection terminal
Katalogzg./Catalogue draw.

AKZO 700/ _ 5,08 V

Polzahl P / pols P	Artikel / Article
2	AKZO 700/2 5,08 V
3	AKZO 700/3 5,08 V
4	AKZO 700/4 5,08 V
5	AKZO 700/5 5,08 V

Ä.Nr./ Alt.No:

Datum/ Date:

DISK: 2604462.idw
Datum/Date: 12.11.2020 BSCH/JL



A Phoenix Mecano Company